

HFW 系列气流分级机

Series HFW Pneumatic Classifier

! " # (Work Principle):

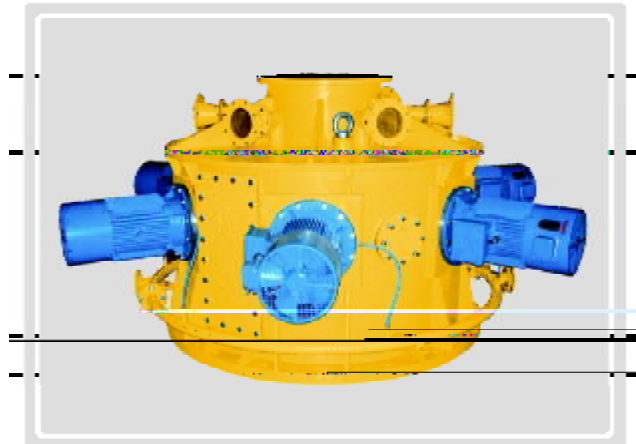

Classifying system is composed of Classifier Cyclone separator, dust collector, and draft fan. Under the effect of draft fan, materials go into the classification area with rising air from the feed input at the bottom of classifier. Under the effect of strong centrifugal force caused by the high-speed rotary turbine role, coarse particles and fine particles separated. The fine particles meeting the requirements of particle size go into the cyclone separator or dust collector via the gap of classifier leaves. Coarse particles along with part of fine particles will be fined to powder immediately after impacting the wall and then fall down to the secondary air hole. Under the washing effect of secondary wind, coarse particles and fine particles separate. Fine particles go up to the classification area to be classified second time, while coarse particles go down to discharge from the outlet.

\$ % & ' (Performance Features):

! D97" 3# 150 \$ % & ' () * + , - .
 / O 1 2 3 O 4 6 0 % # 9 0 % / O 5 6 7 8 9 : ; < 5 = 9 :
 > / O ? @ > A
 B C D E F G H I J K L H M N
 O P Q R S O P T U V W L X Y Z [.
 \] T ^ _ : ` a 40mg/m³, b c d e Q e f g ` h 75dB(A)

Classified products size to D97: 3-150 micrometers, adjustable products granularity-level, extremely convenient to replace species.

Classification efficiency (extraction rate) 60%-90%, which is influenced by materials and consistent of the particles meeting the size; with good mobility and high consistent of the particles meeting the size, the materials classification efficiency is high; while without those, the efficiency is low.

High speed and top-cutting precision. Multi-level classification machine can be cascaded, and production of various products size.

Control system employs programmed control to indicate real-time operational status that is easy to operate.

System operation under negative pressure, dust emissions is not exceeding to 40mg/m³ and with noise-eliminator to confirm it is no more than 75dB (A).

() * + , Application-

ijkl hlmn lo, p qrs tu vw xv yz { | n 4 } ~ • ! " #
S %& ' & () * + S { T,

Widely used for chemical, minerals (especially applicable for non- mineral products classification, such as calcium carbonate, kaolin quartz, talc, mica, etc), metallurgy, abrasive, ceramics, fire- proof material, medicines, pesticides, food, health supplies, and new materials industries.

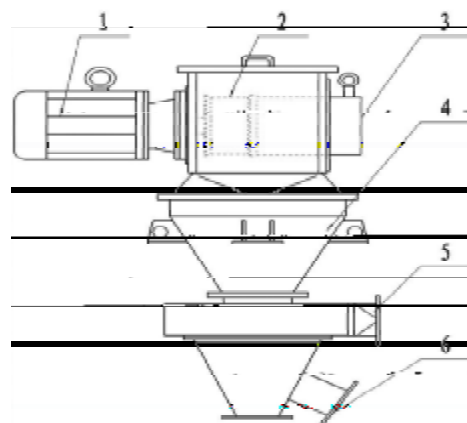
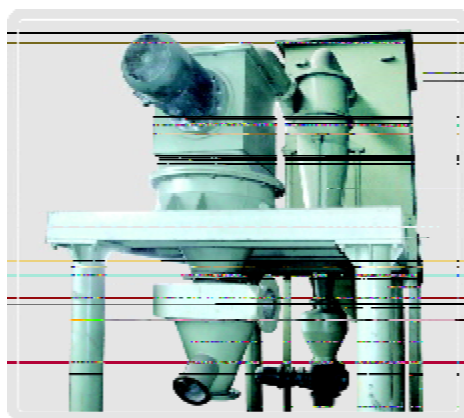

1 - motor 2 classifying wheel 3 fine powder discharge
4 . / chamber 5 secondary air input 6 coarse material outlet

/ O 1 2 3 4 5 6 7 8, Technical parameters for multi-rotors-

| O 1 2 3 Model 7 8 Parameters | HFW3315 | HFW4315 | HFW6315 |
|---------------------------------|----------|----------|----------|
| 4 4 T/h Processing capacity | 1# 5 | 2# 8 | 3# 10 |
| d97: um Products Size | 3# 45 | 3# 45 | 3# 45 |
| / O % Classifying Percentage | 60# 90 | 60# 90 | 60# 90 |
| 5 6 0 kW General Power | 135# 155 | 170# 190 | 250# 290 |

9 O 1 2 3 4 5 6 7 8, Technical parameters for Single- rotor-

| O 1 2 3 Model 7 8 Parameters | HFW140 | HFW200 | HFW220 | HFW260 | HFW315 | HFW330 |
|---------------------------------|---------|---------|---------|-----------|-----------|-----------|
| 4 4 T/h Processing capacity | 20# 200 | 50# 500 | 50# 600 | 100# 1500 | 200# 2000 | 300# 2500 |
| d97: um Products Size | 3# 45 | 3# 45 | 3# 45 | 3# 45 | 3# 45 | 3# 45 |
| / O % Classifying Percentage | 60# 80 | 70# 85 | 70# 85 | 60# 80 | 70# 85 | 60# 80 |
| 5 6 0 kW General Power | 16# 19 | 20# 27 | 21# 28 | 22# 30 | 50# 61 | 53# 65 |